



# Microfluidics™

Superior Knowledge | Superior Results



## LM10 Microfluidizer™ High Shear Fluid Processor

# LM10 Microfluidizer™ High Shear Fluid Processor

## Digitally Controlled Lab Unit For Small Sample Material Processing

**Microfluidizer™** technology efficiently converts fluid pressure into shear forces, leading industry performance standards in high pressure processing.

A unique solution to maintaining consistent process pressure ensures 100% of your material gets exactly the same treatment. Whether you are working with small-scale lab batches or production volumes, the Microfluidizer processor is unmatched in submicron particle/droplet size reduction, cell disruption, product yield, and guaranteed process scale up.



High efficiency cell disruption with minimal protein denaturation

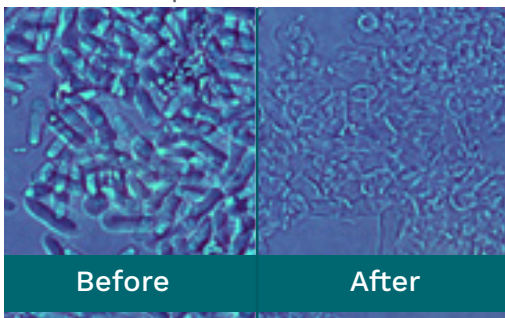

### Recommended For:

- ◆ Emulsions
- ◆ Dispersions
- ◆ Liposomes
- ◆ Cell Disruption
- ◆ Fine Particle Deagglomeration

### Unique Benefits of the LM10

- ◆ Achieve unmatched particle/droplet size reduction or cell disruption performance at lower process pressures
- ◆ Precise temperature control
- ◆ Higher product yields after sterile filtration with tighter particle size distribution
- ◆ Save on development time in pilot/production scale with linear volumetric scale-up
- ◆ Enhanced repeatability with easy-to-use digital pressure control
- ◆ Improved experimental reliability with real-time temperature monitoring
- ◆ Ensure dependable process performance over time with maintenance reminder and operator alerts
- ◆ Calibration making it possible to use a variety of compressor sizes



# LM10 Microfluidizer™ High Shear Fluid Processor

## Operating Principle

The LM10 Microfluidizer processor contains an intensifier pump designed to supply the desired pressure at a constant rate to the product stream. As the pump travels through its pressure stroke, it drives the product at constant pressure through the precisely defined fixed-geometry microchannel within the Interaction Chamber™.

As a result, the product stream accelerates to high velocities, creating shear rates within the product stream that are orders of magnitude greater than any other conventional means. All of the product experiences identical processing conditions, producing the desired results, including: uniform particle and droplet size reduction (often submicron), deagglomeration and high-yield cell disruption.

A removable cooling coil and a cooling bath are incorporated into the design to promote optimal temperature control.

## Standard Features

- ◆ 300 ml glass reservoir
- ◆ Ceramic Interaction Chamber
- ◆ Cooling coil and bath assembly
- ◆ Easily autoclavable
- ◆ Two modes of operation for various compressor sizes
- ◆ Calibrate the processor to specific compressor

## Options

- ◆ Diamond interaction Chambers
- ◆ Larger capacity glass or stainless steel reservoirs
- ◆ Product inlet and outlet thermocouple options
- ◆ Recirculation assembly
- ◆ Auxiliary Processing Module™ (APM™)

## Specifications

Pressure Range	Up to 23,000 psi (1,546 bar)
Minimum Sample Size	30 ml
Flowrate Range	Free Mode = 250-600 ml/min Regulated Mode = 55-100 ml/min
Electrical Power Requirement	85-260VAC, 50/60Hz, 5A
Pump Actuator	Pneumatically Driven
Air Requirements for continuous operation (Delivered to Microfluidizer processor)	Free Mode = 57 scfm @ 120 psi (27 l/s @ 8.3 bar) Regulated Mode = 13 scfm @ 120 psi (6 l/s @ 8.3 bar)
Noise Level	<80dB TWA
Dimensions (W x H x D)	19" x 17" x 27" (48cm x 43cm x 69cm)
Weight	75 lbs (34 kg)

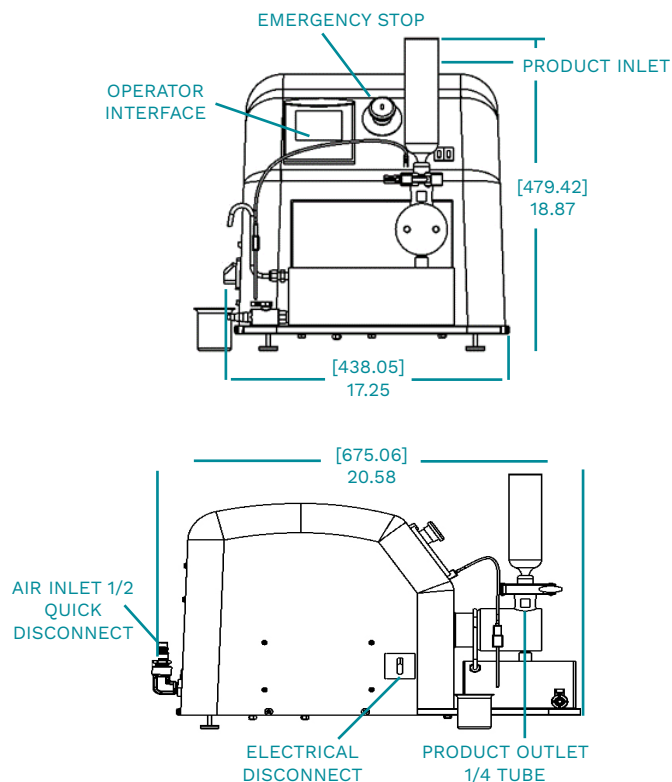



Microfluidics International Corporation  
90 Glacier Drive, Suite 1000,  
Westwood, MA 02090, USA

Tel: 617-969-5452 • 800-370-5452  
Fax: 617-965-1213

Email: [mixinginfo@idexcorp.com](mailto:mixinginfo@idexcorp.com)  
Web: [www.microfluidics-mpt.com](http://www.microfluidics-mpt.com)

---

**Industry Leading Insights & News:**  
<https://www.microfluidics-mpt.com/blog>



Material Processing Technologies