

LCR Meters

SR715 and SR720 — LCR meters with RS-232 interface



SR715/SR720 LCR Meters

- **0.05 % basic accuracy (SR720), 0.2 % (SR715)**
- **5-digit display of L, C, R and Q or D**
- **Test frequencies to 100 kHz (SR720)**
- **Up to 20 measurements per second**
- **Binning and limits for part sorting**
- **External capacitor bias up to 40 V**
- **RS-232 computer interface**
- **GPIB and Parts Handler interfaces (opt.)**

• **SR715 ... \$1295 (U.S. list)**

• **SR720 ... \$1995 (U.S. list)**

The SR715 and SR720 LCR Meters measure passive components with as little as 0.05 % error. These easy-to-use instruments are quick to setup, adjust and calibrate. The SR715 and SR720 are ideal for applications such as incoming inspection, quality control, automated test and general benchtop use.

Front-Panel Display

A 5-digit LED display shows measured values, entered parameters, instrument status and user messages. When making measurements, the major parameter (L, C or R) is shown on the left display and the appropriate minor parameter (Q, D or R) is shown on the right display.

Making Measurements

Measurements can be performed at test frequencies of 100 Hz, 120 Hz, 1 kHz, 10 kHz and 100 kHz (SR720 only). A built-in drive voltage can be set to preset values (0.1, 0.25 and 1.0 V) or adjusted from 0.1 to 1.0 V in 50 mV increments.

Measurements are taken at rates of 2, 10 or 20 samples per second. Consecutive readings can be averaged between two and ten times for increased accuracy. Both series or parallel equivalent circuit models of a component are supported. Capacitor measurements use either the internal 2.0 VDC bias or an external DC source of up to 40 volts.

Simple to Operate

The power and flexibility of the SR715/720 does not come at the expense of ease-of-use. A convenient AUTO measurement mode automates the selection of setup parameters and quickly determines the appropriate device model for whatever component is being measured. Up to nine instrument setups can be stored in non-volatile memory for quick recall at a later time.



SR728 BNC Adapter

Convenient Calibration

The SR715 and SR720 make it simple to compensate for lead impedance and stray fixture and cable capacitance. The null calibration procedure automatically corrects both open and short circuit parameters at all frequencies and all ranges.

Binning

The SR715 and SR720 have built-in features to aid in component sorting. This is especially useful for production testing, incoming inspection, device matching or when you need to test multiple devices of similar value. The meters allow you to sort components into as many as ten different bins.

The SR715 and SR720 support three types of binning schemes: pass/fail, overlapping and sequential. Pass/fail has only two bins; good parts and everything else. Overlapping (or



SR726 Kelvin Clips

nested) bins have one nominal value and are sorted into progressively larger bins (i.e., $\pm 1\%$, $\pm 2\%$, $\pm 3\%$). Sequential bins can have different nominal values, each separated by a percentage or a nominal value and asymmetrical limits. Binning parameters are also easily stored in non-volatile RAM for quick setup in production environments.

Test Fixtures

The SR715 and SR720 have a kelvin fixture which uses two wires to carry the test current and two independent wires to sense the voltage across the device under test. This prevents the voltage drop in the current carrying wires from affecting the voltage measurement. Radial components are simply inserted into the test fixture, one lead in each side. Axial devices require the use of the axial fixture adapters (provided). Surface-mount devices, or components with large or unusually shaped leads, can be measured with optional SMD Tweezers (SR727) or Kelvin Clips (SR726). The tweezers and clips attach directly to the LCR meter's front-panel test fixture. An optional BNC Fixture Adapter (SR728) allows you to connect a remote fixture or other equipment through one meter of coaxial cable.



SR727 Surface Mount Tweezers

Rear Panel

Two rear-panel input connections are provided for an external bias voltage. Voltages as high as 40 VDC can be used. An optional handler interface provides control lines to a component handler for sorting. A standard RS-232 interface allows complete control of all instrument functions by a remote computer. A GPIB interface is included with the handler option.



SR715/SR720 rear panel (with opt. 01)

Measurement modes	Auto, R+Q, L+Q, C+D, C+R
Equivalent circuit	Series or Parallel
Parameters displayed	Value, Deviation, % Deviation or Bin Number (Deviation and % Deviation are calculated relative to a stored value.)
Basic accuracy	SR715: 0.2 %, SR720: 0.05 % (see graphs for details)

Measurement Range

(R+Q mode)	
R	0.0001 Ω to 2000 M Ω
Q	0.00001 to 50
(L+Q mode)	
L	0.0001 μ H to 99999 H
Q	0.00001 to 50
(C+D mode)	
C	0.0001 pF to 99999 μ F
D	0.00001 to 10
(C+R mode)	
C	0.0001 pF to 99999 μ F
R	0.00001 Ω to 99999 k Ω

Electrical

Test frequency	Fixed frequencies at 100 Hz, 120 Hz, 1 kHz, 10 kHz (SR715 and SR720), 100 kHz (SR720 only)
Frequency accuracy	\pm 100 ppm
Drive voltage	Preset levels: 0.10, 0.25, 1.0 Vrms Vernier: 0.1 to 1.0 Vrms with 50 mV resolution
Drive level accuracy	\pm 2 %
Bias voltage	Internal: 2.0 VDC \pm 2 % External: 0 to +40 VDC, fused at 250 mA

Features

Averaging	2 to 10 measurements
Measurement rate	Slow, Medium, Fast: 2, 10 or 20 measurements per second at test frequencies of 1 kHz and above and about 0.6, 2, 4 or 6 measurements per second at 100 Hz and 120 Hz.
Ranging	Auto or Manual
Triggering	Continuous, manual or remote over RS-232, GPIB or Handler interface
Binning	Up to 8 pass bins, QDR and general fail bins, defined from the front panel or over the computer interfaces. Binning setup may be stored in non-volatile memory.

Fixture

Fixture	4-wire kelvin fixture for radial leaded parts with adapters for axial leaded parts.
Fixture protection	Protected up to 1 Joule of stored energy and 200 VDC (for charged capacitors). Fused at 0.25 A output current for biased measurement.

Calibration

Zeroing	Open and short circuit compensation
Compensation limits	Short: R <20 Ω , Z <50 Ω , Open: Z >10 k Ω

General

Store and recall	Store/recall up to nine complete instrument setups.
RS-232	Standard interface. All instrument functions can be controlled or read over the interface.
GPIB and Handler	Optional IEEE-488.2 and Handler interface. Handler interface uses a DB25 connector, positive logic for binning and control.
Operating temperature	0 $^{\circ}$ C to 35 $^{\circ}$ C
Relative humidity	<85 %
Power	20 W, 100/120/220/240 VAC, 50 or 60 Hz
Dimensions	13.5" \times 4" \times 14" (WHD)
Weight	10 lbs.
Warranty	One year parts and labor on defects in materials and workmanship

Ordering Information

SR715	10 kHz LCR meter w/ RS-232	\$1295
SR720	100 kHz LCR meter w/ RS-232	\$1995
Option 01	GPIB and parts handler interface	\$495
SR726	Kelvin clips	\$300
SR727	Surface mount tweezers	\$300
SR728	4-wire BNC adapter	\$200

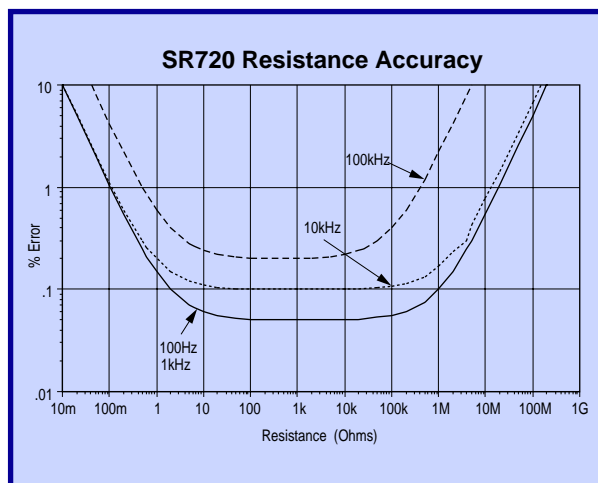
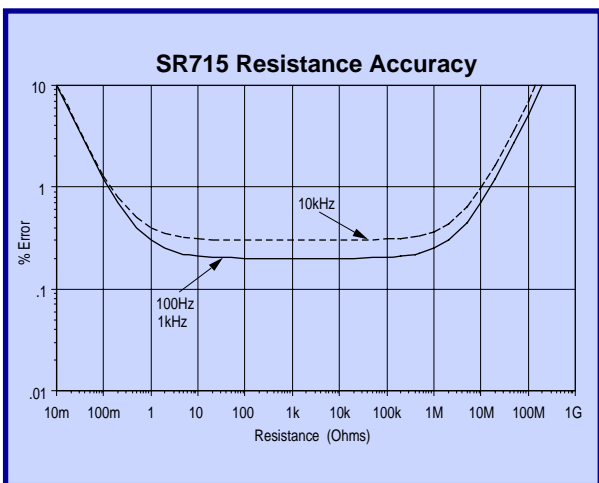
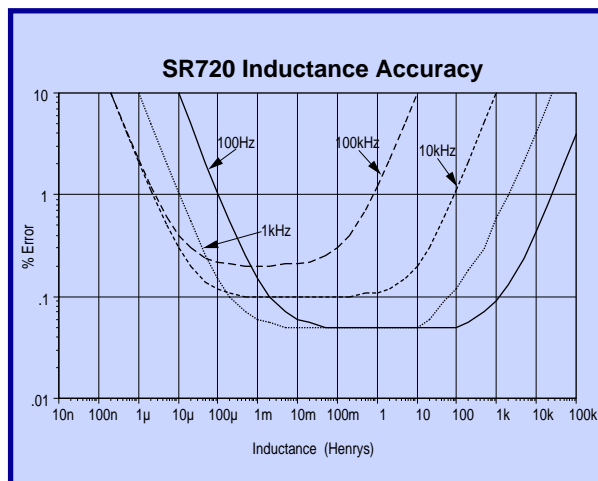
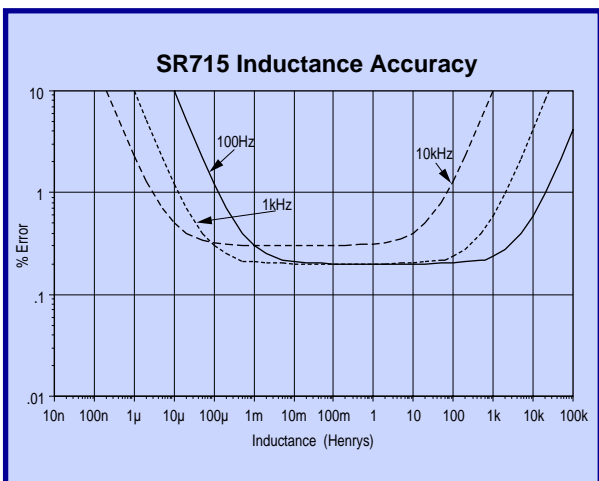
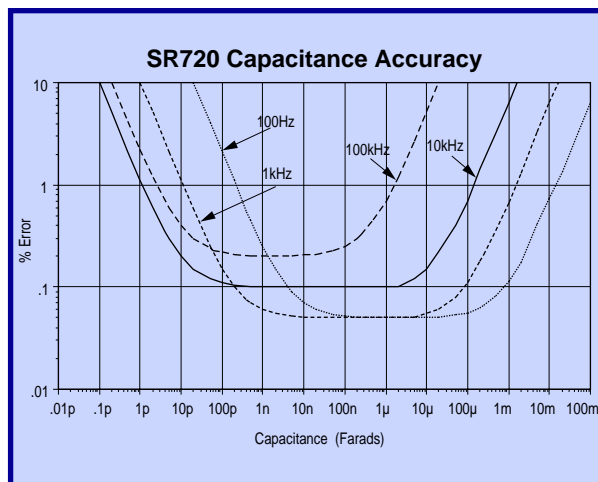
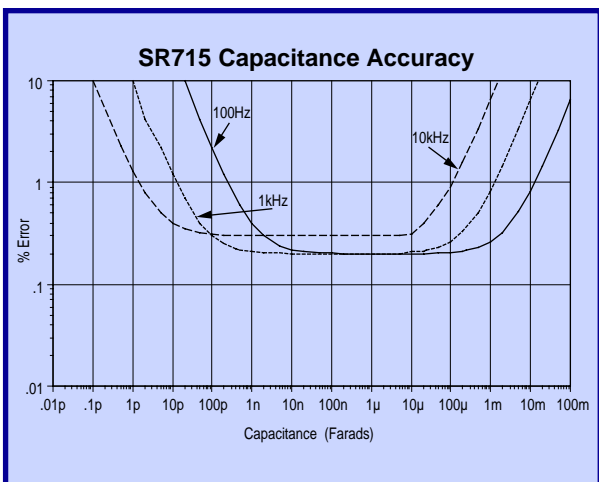

Ideal Device Models

All non-ideal passive devices (resistors, inductors and capacitors) can be modeled as a real component (resistor) either in series or in parallel with a reactive component (capacitor or inductor). The impedance of these components change as a function of frequency. The series and parallel models are mathematically equivalent and can be transformed back and forth with the equations shown. The SR715 and SR720 can switch between either parallel or series equivalent circuits.

Usually one model is a better representation of the device under operating conditions. The most accurate model depends on the device and the operating frequency. Certain devices are tested under conditions defined by the manufacturer or industry standard. For example, electrolytic capacitors are often measured in series at 120 Hz in the C+R mode, so the

ESR (equivalent series resistance) can be measured. The equivalent series resistance in capacitors includes things like dielectric absorption in addition to the ohmic losses due to leads. It is often listed on data sheets for electrolytic capacitors used in switching power supplies. At high frequencies, the ESR is the limiting factor in the performance of the capacitor.

The quality factor, Q , is the ratio of the imaginary impedance to the real impedance. For inductors, a high Q indicates a more reactively pure component. A low Q indicates a substantial series resistor. Q varies with frequency. With resistors, often all that is stated is that the resistor has low inductance.

The dissipation factor, D , is equal to $1/Q$ and is the ratio of the real impedance to the imaginary impedance. A low D indicates a nearly pure capacitor. D is commonly used when describing capacitors of all types.

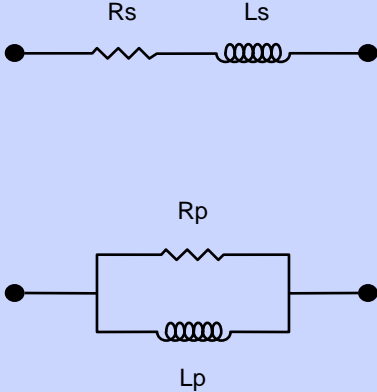

Series Inductor Model: A resistor R_s and an inductor L_s are connected in series.

Parallel Inductor Model: A resistor R_p and an inductor L_p are connected in parallel.

$$Z_s = R_s + j\omega L_s = R_s(1 + jQ) = \omega L_s \left(\frac{1}{Q} + j \right)$$

$$Z_p = \frac{j\omega L_p R_p}{R_p + j\omega L_p} = \frac{R_p(1 + jQ)}{1 + Q^2}$$

$$Q = \frac{R_p}{\omega L_p} = \frac{\omega L_s}{R_s} \quad Q = \frac{1}{D}$$

$$L_s = \frac{Q^2}{1 + Q^2} L_p \quad R_s = \frac{\omega L_s}{Q} \quad R_p = Q\omega L_p$$

$$R_p = \frac{1}{G_p} \quad B_p = -\frac{1}{\omega L_p}$$

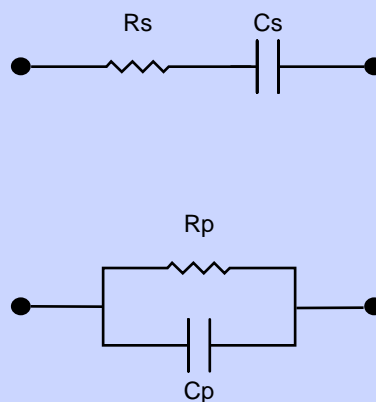
$$Y = G_p - \frac{j}{\omega L_p}$$

Series Capacitor Model: A resistor R_s and a capacitor C_s are connected in series.

Parallel Capacitor Model: A resistor R_p and a capacitor C_p are connected in parallel.

$$Z_s = R_s - j\frac{1}{\omega C_s} = \frac{1}{\omega C_s}(D - j) = R_s \left(1 - \frac{j}{D} \right)$$

$$Z_p = \frac{R_p}{1 + j\omega R_p C_p} = \frac{D^2 R_p + \frac{1}{j\omega C_p}}{1 + D^2}$$

$$D = \omega R_s C_s = \frac{1}{\omega R_p C_p} \quad D = \frac{1}{Q}$$

$$C_s = (1 + D^2) C_p \quad R_s = \frac{D^2}{1 + D^2} R_p$$

$$R_p = \frac{1}{G_p} \quad B_p = \omega C_p$$

$$Y = G_p + j\omega C_p$$